

Features & benefits

Min operating temp of -100°C with TE cooling

Unparalleled TE cooling performance for negligible dark current, without the aggravation or safety concerns associated with LN₂.

QE_{max}. 95% from back-illuminated sensor (BV model)

Highest photon collection efficiency.

Ultra low noise readout

Intelligent low-noise electronics offer the most 'silent' system noise performance available.

Multi-Megahertz pixel readout

High frame rates achievable.

UltraVac™ - guaranteed hermetic vacuum seal process

Proven reliability and sustained lifetime performance.

Single window design

Maximum photon throughput.

13 x 13µm pixel size

Optimal balance of dynamic range and resolution

USB 2.0 connection

Simple USB 2.0 connection direct from back of camera – no controller box required!

Integrated shutter

C-mount shutter as standard. Close during readout to avoid vertical smear.

Cropped sensor mode

Specialised acquisition mode for continuous imaging with fast temporal resolution.

Enhanced Baseline Clamp

Essential for quantitative accuracy of dynamic measurements.

Andor Solis software / SDK (Linux SDK available)

Friendly Windows user interface offers intuitive acquisition optimization, system integration, automation and advanced data manipulation facilities.

“ Industry-Leading Ultra-Sensitive Imaging Technology ”

Andor's iKon-M 934 series cameras are designed to offer the ultimate in high-sensitivity, low noise performance, ideal for demanding imaging applications.

These high resolution 1024 x 1024 CCD cameras boast up to 95% QE_{max} (BV model), high dynamic range, 13µm pixels and exceptionally low readout noise.

The iKon-M benefits from negligible darkcurrent with industry-leading thermoelectric cooling down to -100°C, enabling use of significantly longer exposure times than offered by any other camera on the market using this same sensor. The iKon-M platform offers Multi-Megahertz readout for more rapid acquisition or fast focusing, along with direct USB 2.0 connectivity to PC.



Camera overview

Active Pixels* ¹	1024 x 1024
Pixel Size (W x H; µm)	13 x 13
Image Area (mm)	13.3 x 13.3
Active Area Pixel Well Depth (e ⁻ , typical)	100,000
Output Saturation (e ⁻ , typical)* ²	200,000
Frame Rate (frames per sec)* ³	2.2
Read Noise (e ⁻ , typical)	
@ 50 kHz	2.5
@ 2.5 MHz	10.3

Quantum efficiency*⁴

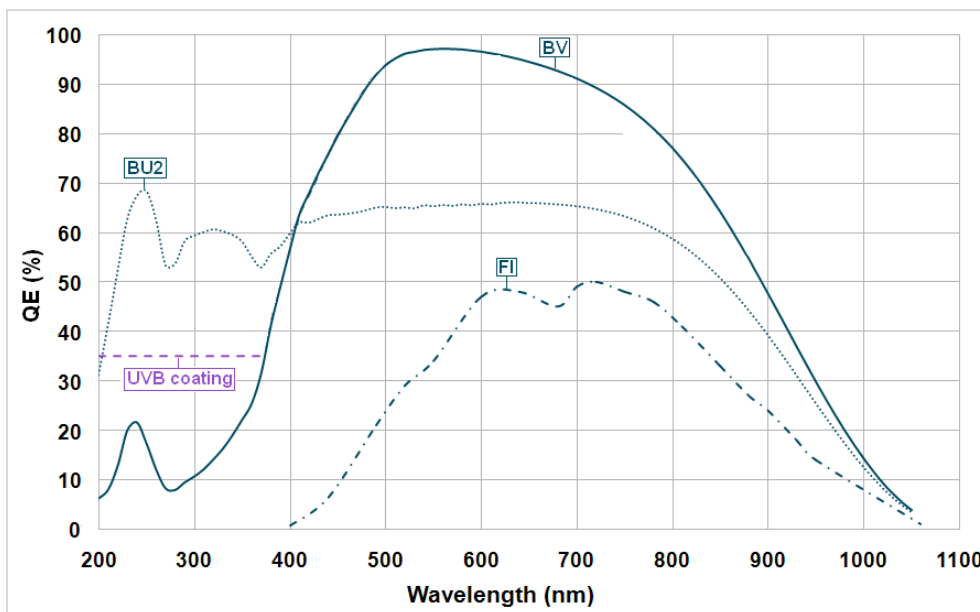

Technical specifications

System characteristics

Dummy Pixels	24, 24, 3, 3
Pixel Readout Rate (MHz)	2.5, 1, 0.05
Linearity (% maximum) ^{*5}	1
Vertical Clock Speed (μ s)	11 to 44 (software selectable)
Software Selectable Sensitivity (e ⁻ per A/D count, typical)	4, 2, 1
Digitization	16 bit (at all readout speeds)
Camera window type	Single quartz window. AR coated on both sides for BV version only.

System readout noise^{*6}

Pixel Readout Rate (MHz)	Readout Noise (e ⁻ , typical)
0.05	2.5
1	8.0
2.5	10.3

Minimum sensor temperatures (typical)^{*7}

Air cooled (ambient air at 20°C)	-80°C
Re-circulator (XW-RECR) (ambient air @ 20°C)	-95°C
Water-cooled (@ 10 °C, 0.75 l / min)	-100°C

Dark current (back-illuminated)

@ -80°C (typical)	0.005e ⁻ /pixel/sec
@ -100°C (typical)	0.00012 e ⁻ /pixel/sec

Operating & storage conditions

Operating Temperature	0°C to 30°C ambient
Relative Humidity	< 70% (non-condensing)
Storage Temperature	-25°C to 55°C

Power requirements

- 5Vdc with 15 Watts
- 7.5Vdc with 30 Watts (PS-25 only)
- \pm 15Vdc with 3 Watts

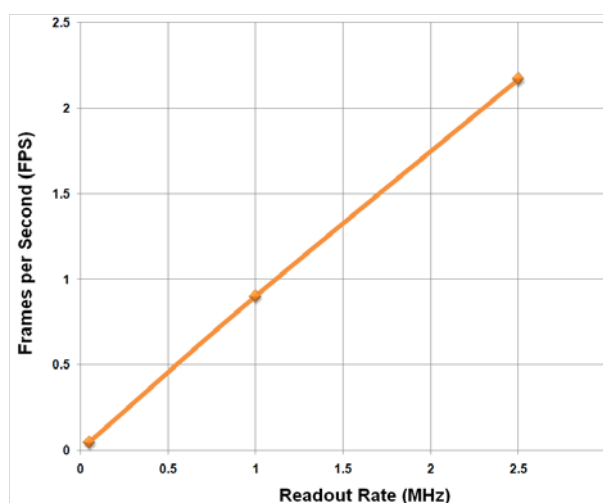
Full frame rate^{*8}Max frames per second^{*9}

Binning	1 MHz			
	Full Frame	512 x 512	256 x 256	128 x 128
1x1	0.9	1.77	3.45	6.55
2x2	2.76	4.15	7.09	12.31
4x4	7.05	8.5	13.14	20.84
8x8	14.07	15.17	21.66	31.27

Binning	2.5 MHz			
	Full Frame	512 x 512	256 x 256	128 x 128
1x1	2.17	4.22	8.0	14.5
2x2	5.25	8.71	14.89	24.46
4x4	10.6	15.75	24.58	36.43
8x8	17.79	24.8	35.6	47.87

Computer requirements

To handle data transfer rates of 2.5 MHz readout over extended kinetic series, a powerful computer is recommended, e.g.:

- 2.4 GHz Pentium (or better) + 1Gbyte RAM
- 32 MB free hard disc to install software
- USB 2.0
- Windows 2000 or better

Need more information? Please contact us at:

International Office	US Office
Phone: +44 28 9023 7126	Phone: 800.296.1579
Fax: +44 28 9031 0792	Fax: 860.290.9566
Japanese Office	Chinese Office
Phone: +81 3 3511 0659	Phone: +86-10-5129-4977
Fax: +81 3 3511 0662	Fax: +86-10-6445-5401

Ordering information & notes

To order the camera you require, please quote one of the following model numbers:

DU934N	BU2	Back illuminated device
	BV	Back illuminated device - AR coated for optimal performance in the visible region
	FI	Standard front illuminated device
	UVB	Back illuminated device with UV coating

The DU934N is supplied with the following power supply:

PS-25	Switchable power supply for <u>maximum</u> air or water cooling, with 2x settings; standard or deep cooling .
--------------	---

The DU934N also requires one of the following software options:

Andor Solis (i)	A ready-to-run Windows 2000 or XP-based package with rich functionality for data acquisition and processing.
Andor SDK	A ready-to-run Windows 2000 or XP-based package with rich functionality for data acquisition and processing. Available for Windows 2000 or XP and Linux.

The following accessories are available for use with the DU934N:

XW-RECR	Re-circulator for enhanced cooling performance
XW-CHIL-150	Chiller/re-circulator for maximum cooling performance
XU-TRAN	USB 2.0 Ranger - Transmitter
XU-RECR	USB 2.0 Ranger - Receiver
XU-POWR	15W External Power Supply. NOTE: The XU-TRAN & XU-RECR each need their own supply.
OA-CCFM	C-mount to Canon F-mount adapter
OA-CNAF	C-mount to Nikon F-mount adapter
OA-COFM	C-mount to Olympus F-mount adapter
OA-CTOT	C-mount to T-mount adapter
OA-ECAF	Auto ext. tubes (set of 3) for Canon AF
OA-ECMT	Auto ext. tubes (set of 3) for C-mount
OA-ENAF	Auto ext. tubes (set of 3) for Nikon AF

Applications

- Astronomy
- Biochip reading
- Bioluminescence/Chemiluminescence
- Bose-Einstein Condensation (BEC)
- Fluorescence microscopy
- High throughput screening
- Hyper-spectral imaging
- Laser Induced Fluorescence (LIF)
- Neutron Radiography
- Pressure sensitive paints
- Raman imaging
- Semiconductor analysis

Specifications are subject to change without notice

◆1	Edge pixels may exhibit a partial response.
◆2	The output saturation that is actually accessible by the CCD system is dependent upon the sensitivity setting & binning mode selected.
◆3	Based on a horizontal pixel readout rate of 2.5 MHz and a vertical shift speed of 11 μ s.
◆4	Quantum efficiency of the CCD sensor as measured by the CCD Manufacturer (shown at room temperature)
◆5	Linearity is measured from a plot of counts vs. signal up to the saturation point of the system. Linearity is expressed as a percentage deviation from a straight line fit.
◆6	System Readout noise is for the entire system. It is a combination of CCD readout noise and A/D noise. Measurement is for Single Pixel readout with the CCD at a temperature of -50°C and minimum exposure time under dark conditions. Noise values will change with pre-amplifier gain (PAG) selection. Values quoted are measured with highest available PAG setting.
◆7	Cooling is provided by the use of an external, mains driven, power supply. Minimum temperatures listed are typical values. Systems are specified in terms of minimum dark current achievable rather than absolute temperature.
◆8	The graph shows the full frame rates possible when reading out the sensor at 2.5, 1 and 0.05 MHz pixel readout rates, using 11 μ s vertical clock speed.
◆9	Shown are the frame rates at 1 MHz and 2.5 MHz digitization rates for a range of binning or array size combinations. All measurements are made with 11 μ s vertical shift speed. It also assumes internal trigger mode of operation and 'zero' exposure time.

Note: The iKon-M has integrated shutter / shutter driver circuitry.



Solar eclipse.

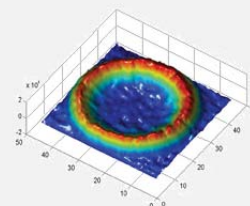

Surface intensity plot showing bioluminescence output.

Dimensions in mm (inches)

Weight: 2.6 Kg [5.7 lb]

Side / front view

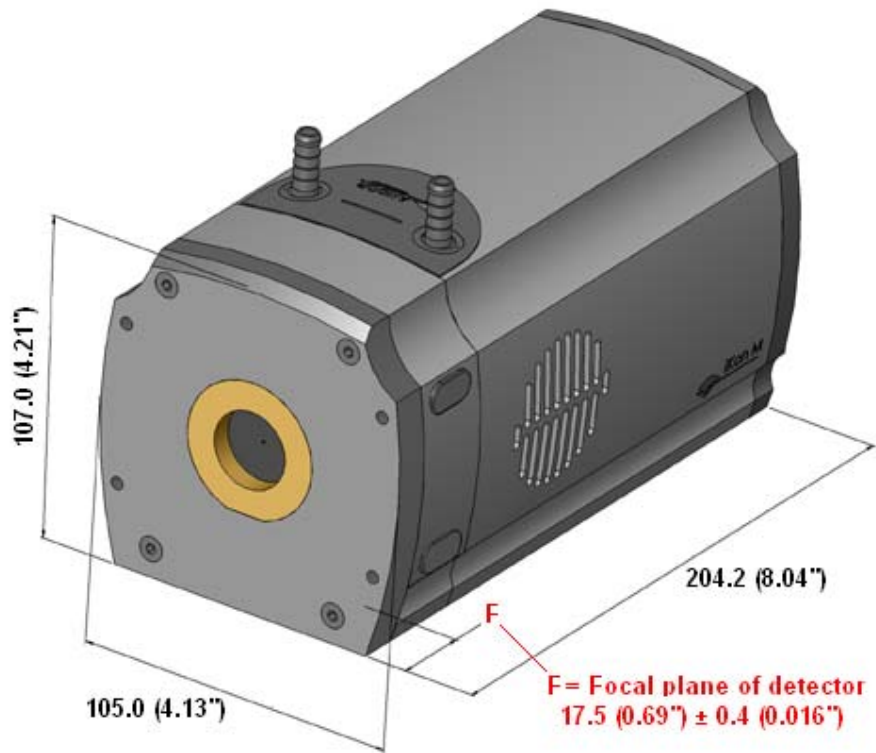

Front face

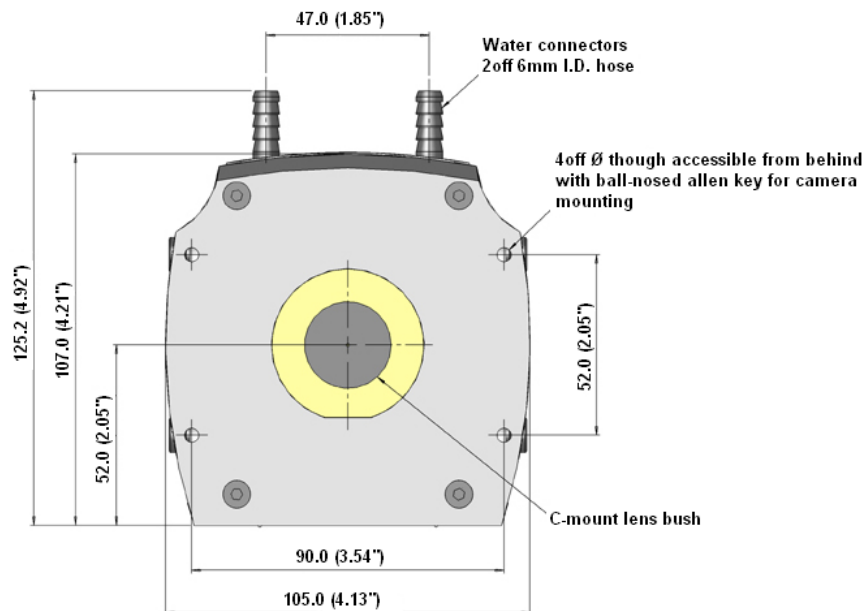

Mounting hole locations

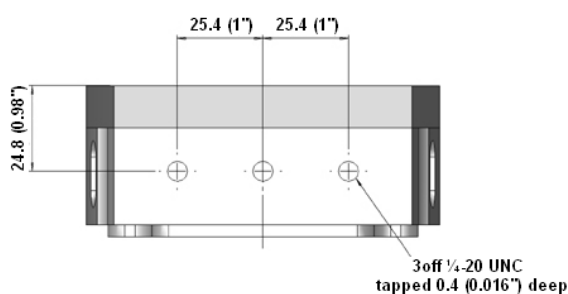

Rear view showing connections