

Time-Resolved

Features and Benefits

- **USB 2.0 connection**
Simple Plug & Play connection
- **Multi-MHz Readout speeds**
Rapid image capture for fast transition phenomena analysis and “focusing mode”
- **Integrated Digital Delay Generator**
With comprehensive software controls
- **Close-Coupled Gating**
< 2 ns true optical gating speeds - ultimate temporal resolution
- **Lowest insertion delay**
As low as 19 ns
- **Fibre-optic coupling**
High optical throughput without vignetting
- **IntelliGate™¹**
MCP gating for On/Off ratios >10⁹ in the UV
- **Photocathode gating rate up to 500 kHz**
Increased Signal to Noise ratio for high speed laser-based experiments
- **Cropped sensor mode**
Specialized acquisition mode to achieve fastest image acquisition rate
- **High resolution Gen 2 and 3 intensifiers**
Highest available intensifier resolution with up to QE 50% and sensitivity options from 120 nm to 1,100 nm
- **Thermo-Electric cooling down to -40°C**
Ideal for low-light applications
- **Real-time control**
Intuitive Windows user interface for real-time acquisition optimization
- **Photocathode dry gas purge port**
Provides further EBI reduction for low-light applications

Highest performance platform for fast gated, high resolution Spectroscopy

Andor's iStar 340T intensified CCD camera series is designed to offer the ultimate integrated detection solution for high resolution, ns-scale time-resolved Spectroscopy. The high resolution 2048 x 512 array with 13.5 µm pixel size offers a 4:1 aspect ratio which is ideally suited for use with Andor's Shamrock Czerny-Turner spectrograph series and accessories.

It boasts Multi-MHz readout along with laptop-friendly, USB 2.0 connectivity and a fully integrated, software-controlled **Digital Delay Generator (DDG™)**. This allows seamless integration of complex experiments at the touch of a button, with full timing and gain control through a single interactive interface. Gen 2 & 3 image intensifiers with entrance input window and phosphor options are available to match wavelength range requirements from 120 nm to 1,100 nm and minimum gating speeds requirements < 2 ns.

Specifications Summary

	Ø18 mm	Ø 25 mm
Effective active area of CCD	18 x 6.9 mm	25 x 6.9 mm
Active pixels	1330 x 512	1850 x 512
Fibre optic taper magnification	1:1	
Effective CCD pixel size	13.5 x 13.5 µm (100% fill factor)	
Read noise	As low as 5 e ⁻	
Spectral rate (spectra/sec, max.)	Up to 1,100	
Useful photocathode spectral range	120 - 1100 nm*	
Photocathode QE	Up to 50%*	Up to 45%*
Minimum optical gate width	< 2 ns*	
Digitization	16 bit	

* Dependant on intensifier type

Specifications - Gen 2 Image Intensifiers *2

Photocathode model	18*-03	18*-04	18*-05 †	18H-13	18H-83	18*-E3	25*-03 ¹
Useful aperture	Ø 18 mm						Ø 25 mm
Input window	Quartz	Quartz	MgF ₂	Quartz	Quartz	Quartz	Quartz
Photocathode type	W-AGT	W-AGT	W-AGT	WR	UW	WE-AGT	W-AGT
Minimum guaranteed peak QE @ room temperature *3	18	18	15	13.5	25	22	16
Wavelength range	180 - 850 nm	180 - 850 nm	120 - 850 nm	180 - 920 nm	180 - 850 nm	180 - 850 nm	180 - 850 nm
Image intensifier resolution limit *4	25 µm	30 µm	25 µm	25 µm	25 µm	25 µm	35 µm
Phosphor type [decay time to 10%]	P43 [2 ms]	P46 [200 ns]	P43 [2 ms]	P43 [2 ms]	P43 [2 ms]	P43 [2 ms]	P43 [2 ms]
Minimum optical gate width (ns) *5, 6							
U (Ultrafast)	< 2	< 2	< 5	-	-	< 2	< 3
F (Fast)	< 5	< 5	< 10	-	-	< 5	< 7
H (High QE)	-	-	-	< 50	< 100	-	-
Maximum relative gain *7	> 1000	> 500	> 1000	> 850	> 500	> 300	> 1000
Maximum photocathode repetition rate (with Intelligate™ OFF)	500 kHz (continuous)						
Maximum photocathode repetition rate (with Intelligate™ ON)	5 kHz (continuous)						
Equivalent Background Illuminance (EBI)	< 0.2 e-/pix/sec			< 0.4 e-/pix/sec	< 0.2 e-/pix/sec		

* Substitute with appropriate gate width option, e.g. 18F-03 (please refer to page 5 for detailed ordering information)

† Available with VUV-compatible spectrograph interface

Quantum Efficiency Curves for Gen 2 Image Intensifiers **3

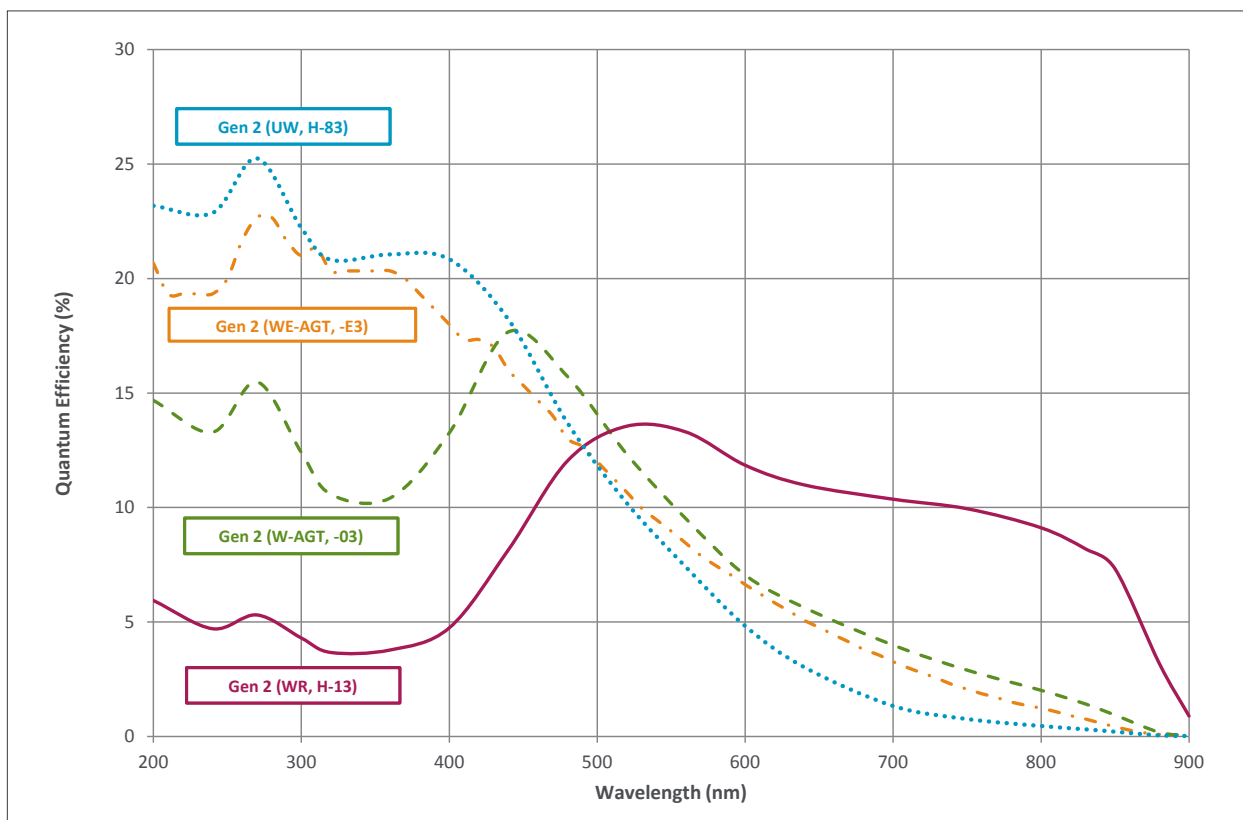

Specifications - Gen 3 Image Intensifiers *2

Photocathode model	18*-63	18*-73	18*-93	18*-A3	18*-C3
Useful aperture	Ø 18 mm				
Input window	Glass	Glass	Glass	Glass	MgF ₂ + F/O + Lumogen
Photocathode type	HVS	VIH	NIR	EVS	BGT
Peak QE @ room temperature *3	> 47.5	> 25.5	> 5	> 40	> 17
Wavelength range	280 - 760 nm	280 - 910 nm	380 - 1090 nm	280 - 810 nm	< 200 - 910 nm
Image intensifier resolution limit *4	30 µm	30 µm	30 µm	30 µm	40 µm
Phosphor type [decay time to 10%]	P43 [2 ms]				
Minimum optical gate width (ns) *6					
U (Ultrafast)	< 2	< 2	< 3	< 2	< 3
F (Fast)	< 5	< 5	< 5	< 5	< 5
Maximum relative gain *7	> 200				
Maximum photocathode repetition rate (with Intelligate™ OFF)	500 kHz (continuous)				
Maximum photocathode repetition rate (with Intelligate™ ON)	5 kHz (continuous)				
Equivalent Background Illuminance (EBI)	< 0.1 e-/pix/sec	< 0.3 e-/pix/sec	< 2 e-/pix/sec	< 0.2 e-/pix/sec	< 0.3 e-/pix/sec

* Substitute with appropriate gate width option, e.g. 18U-63 (please refer to page 5 for detailed ordering information)

Quantum Efficiency Curves for Gen 3 Image Intensifiers *3, *8

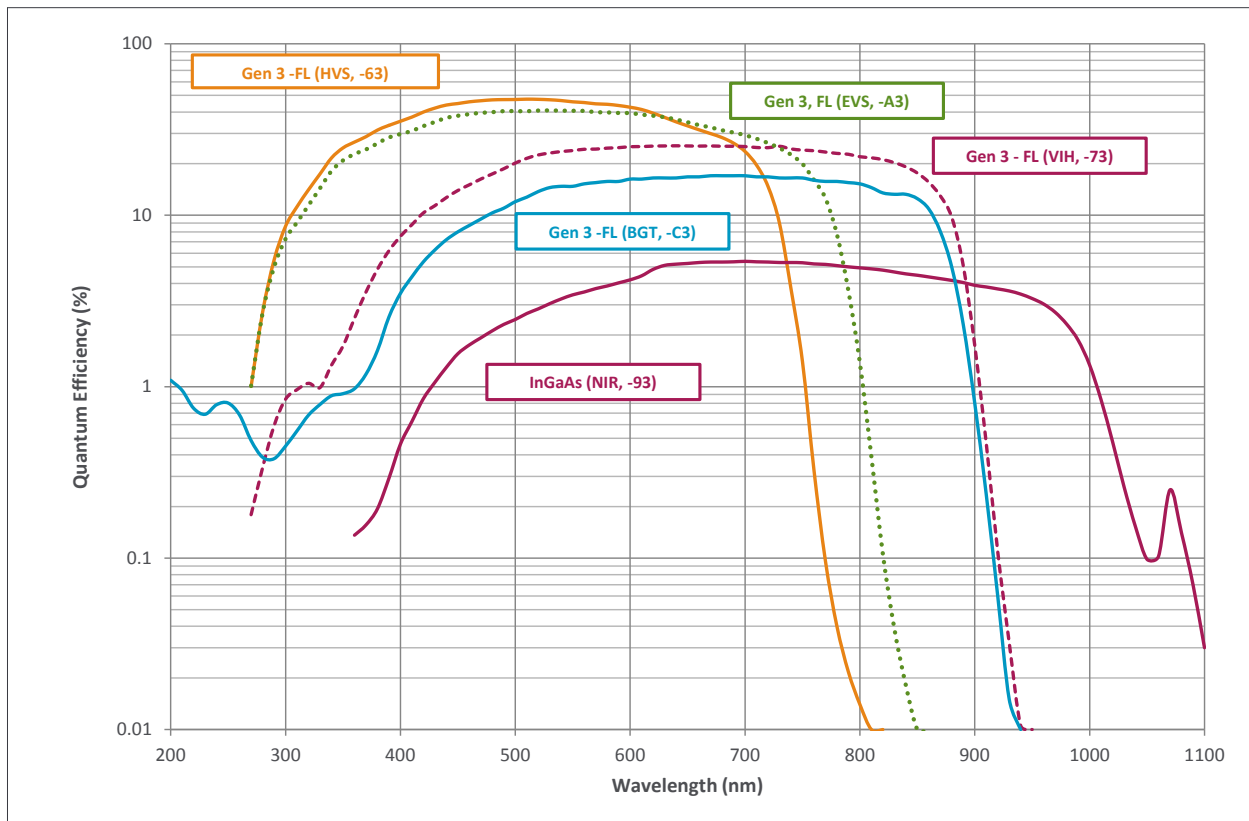

CCD Specifications *2

Total CCD matrix size	2048 x 512			
Fibre optic taper magnification	1:1			
Effective CCD pixel size	13.5 x 13.5 µm with 100% fill factor			
Effective active area	Ø 18 mm 18 x 6.9 mm		Ø 25 mm 25 x 6.9 mm	
Image pixel well depth	100,000 e ⁻			
Register well depth	150,000 e ⁻			
Read noise e ⁻ *9	50 kHz	1 MHz	3 MHz	5 MHz
Typical	6	9	12	Focusing mode only
Maximum	8	12	18	-
Vertical shift speeds	6.5 to 25.7 µs (software selectable)			
Maximum frame and spectral rates	Frame 2.5 full fps 5.6 fps (2x2 binning)	FVB 135 sps	Crop Mode (10 rows) 184 fps 1,825 sps	Fast Kinetics (4 rows) 16,950 Hz
Sensitivity	1 to 5 e ⁻ /count (software selectable)			
Linearity *10	Better than 99%			
Minimum temperature air cooled [dark current, e ⁻ /pixel/sec] Coolant chiller, coolant @ 10°C, 0.75 l/min [dark current, e ⁻ /pixel/sec]	Ø 18 mm -30°C [0.2] -40°C [0.1]		Ø 25 mm -25°C [0.4] -35°C [0.15]	

Internal Digital Delay Generator (DDG™) Key Functions

Gate pulse delay & width	<ul style="list-style-type: none"> Adjustable from 0 ns to 10 s in 10 ps steps Software controlled, pre-programmed or real-time
Trigger Outputs	
Output A, B and C	<ul style="list-style-type: none"> 3x output, +5V CMOS level with 50 Ω source impedance; can drive 5V into a non-terminating load or 2.5V into 50 Ω load; output synchronized triggers for auxiliary equipment, e.g. lasers, flash lamps, National Instrument™ hardware Individual delays control from 0 ns to 10 s in 10 ps steps Configurable Polarity Software controlled, pre-programmed or real-time
Fire	5V CMOS level reference signal for beginning and end of individual CCD exposure
Arm monitor	5V CMOS level reference signal to indicate when system is ready to accept external triggers. Signal goes high when system is ready to accept external triggers (after a readout has finished) and goes low when the exposure is finished
Gate & output A, B and C jitter	35 ps rms (relative to external trigger signal)
Trigger Inputs	
External trigger	<ul style="list-style-type: none"> Trigger input for CCD and Digital Delay Generator Up to 500 kHz for Integrate-On-Chip mode Software-configurable Polarity, Termination and Trigger Threshold Fast external software option for most rapid camera response to external trigger (CCD keep clean interruption) – no need for pre-trigger pulse
Direct gate	TTL input for exact external control of photocathode width and timing with smallest insertion delay.
Additional Controls	
Gate monitoring	AC coupling from photocathode to monitor exact photocathode on/off switching and timings
Insertion delay	< 19 ns in direct gate operation

Have you found what you are looking for?

Need a greater spectral rate? The DH334T series cameras offers up to 3,450 spectrum per second.

Need a faster response phosphor for Fast Kinetics? P46 phosphor is available as an option for all models.

Need a taller sensor format? The high resolution DH334T series cameras offer 13.3 mm high field of view.

Need a customized version? Please contact us to discuss our Customer Special Request (CSR) options.

Creating The Optimum Product for You



DH340T-25-F-03
example shown

Step 1. Choose the intensifier diameter



Intensifier Diameter

Intensifier diameter	Code
Ø 18 mm	18
Ø 25 mm	25

Step 2. Choose a minimum gating speed



GATING SPEED
Gating Speed

Gating Speed	Code
High QE, slow gating	H
Fast Gating	F
Ultra Fast Gating	U

Step 3. Select an image intensifier option



Intensifier

Gen 2 Intensifier option	Code
W-AGT photocathode, P43 phosphor	03
W-AGT photocathode, P46 phosphor	04
W-AGT photocathode, MgF ₂ window, P43 phosphor	05
WR photocathode, P43 phosphor	13
UW photocathode, P43 phosphor	83
WE-AGT photocathode, P43 phosphor	E3

Gen 3 Intensifier option	Code
HVS photocathode, P43 phosphor	63
VIH photocathode, P43 phosphor	73
NIR photocathode, P43 phosphor	93
EVS photocathode, P43 phosphor	A3
BGT photocathode, P43 phosphor	C3

Step 4. Select the required accessories and adapters



Accessories & Adapters

Description	Order Code
C-mount lens adaptor	LM-C
F-mount lens adaptor	LM-NIKON-F
Oasis 160 Ultra compact chiller unit	ACC-XW-CHIL-160
6 mm tubing option for ACC-XW-CHIL-160	ACC-6MM-TUBING-2xxxxM
i2c to BNC cable for Shamrock shutter control	ELC-05323
Metric Bracket	ACC-ISTAR-METRIC ADP

In addition to the accessories listed the following special options are also available:

- 90° USB connection
- UV or visible lenses or adapter extension tubes

Please contact your local Sales representative for details of how to order any of these items.

Step 5. Select the required software



Software

The iStar ICCD requires at least one of the following software options:

Solis for Time-Resolved A 32-bit and fully 64-bit enabled application for Windows (XP, Vista, 7 and 8) offering rich functionality for data acquisition and processing. AndorBasic provides macro language control of data acquisition, processing, display and export.

Andor SDK A software development kit that allows you to control the Andor range of cameras from your own application. Available as 32 and 64-bit libraries for Windows (XP, Vista, 7 and 8) and Linux. Compatible with C/C++, C#, Delphi, VB6, VB.NET, LabVIEW and Matlab.

Product Drawings

Dimensions in mm [inches]

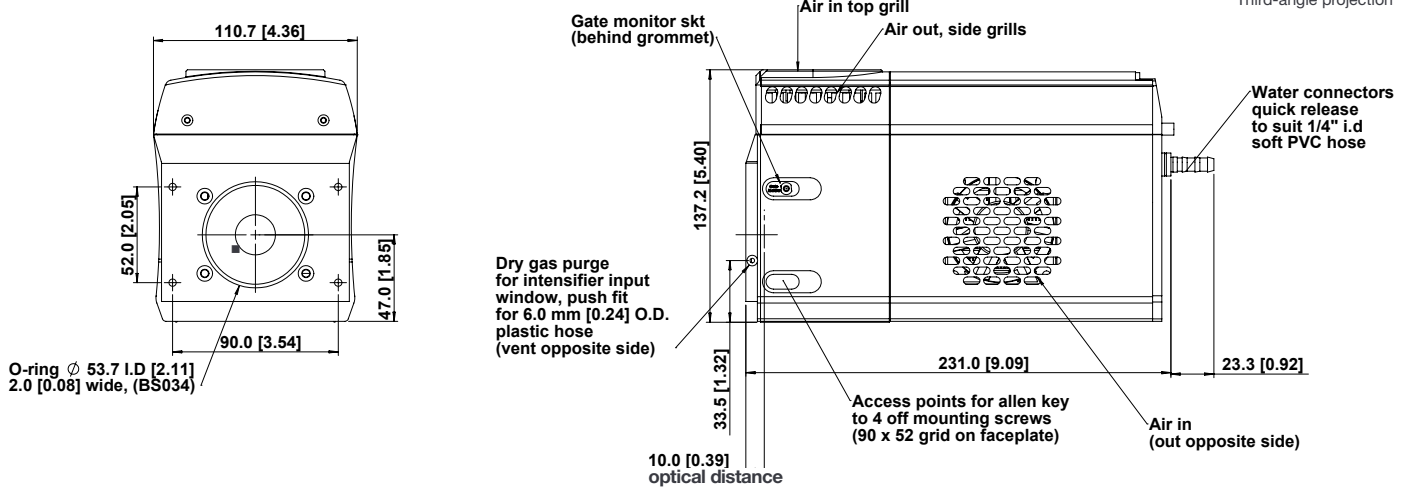
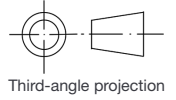

Weight: 4.2 kg [9 lb 4 oz]

■ = position of pixel 1,1

Connecting to the iStar

Camera Control

Connector type: USB 2.0

Logic Input / Output

Connector type: SMA, provided with SMA - BNC cable
 5x outputs: FIRE pulse, Output A, B, C from DDG™ and ARM
 2x inputs: Camera trigger from 3rd party source & direct gate for complete, direct external control of intensifier gating

I²C connector

Compatible with Fischer SC102A054-130, pin-outs as follow:
 1 = Shutter (5V CMOS level with 50 Ω impedance), 2 = I²C Clock (5V), 3 = I²C Data (5V), 4 = +5 Vdc, 5 = Ground

Gate Monitor

1x output: AC coupling to photocathode

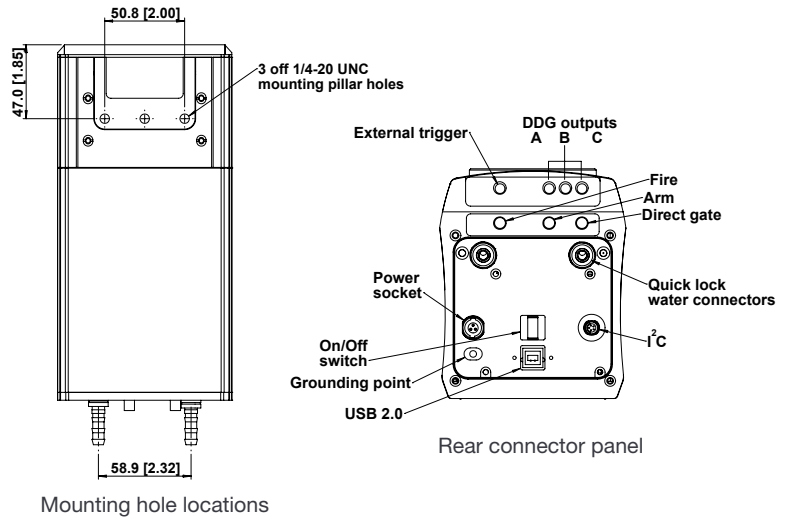

Applications Guide

	Gen 2	Gen 2 UV Enhanced (-05, -83, -E3)	Gen 3*	InGaAs
Plasma Studies	✓	✓	✓	✓
Time Resolved Raman	✓	✓	✓	
Time Resolved Luminescence Spectroscopy	✓	✓	✓	
Laser Induced Breakdown Spectroscopy (LIBS)	✓	✓	✓	
Laser Flash Photolysis	✓	✓	✓	
Transient Absorption Spectroscopy	✓	✓	✓	✓
Time Resolved Photoluminescence Spectroscopy			✓	✓

* Gen 3 typically do not exhibit any UV response - Andor -C3 is constructed with an additional input phosphor interface to provide this UV response.

- ✓ = Suitable
- ✓ = Optimum



Order Today

Need more information? At Andor we are committed to finding the correct solution for you. With a dedicated team of technical advisors, we are able to offer you one-to-one guidance and technical support on all Andor products. For a full listing of our local sales offices, please see: andor.com/contact

Our regional headquarters are:

Europe

Belfast, Northern Ireland
Phone +44 (28) 9023 7126
Fax +44 (28) 9031 0792

Japan

Tokyo
Phone +81 (3) 6732 8968
Fax +81 (3) 6732 8939

North America

Connecticut, USA
Phone +1 (860) 290 9211
Fax +1 (860) 290 9566

China

Beijing
Phone +86 (10) 8271 9066
Fax +86 (10) 8271 9055

Items shipped with your camera

Power Brick, 12V, 120W single line
2x 2m BNC to SMA cable
1x Gate Monitor cable
3 Metre USB cable A to B type, shielded (1 off)
1x Quick launch guide
1x CD containing Andor user guides
1x Individual system performance booklet

Regulatory Compliance

Compliant with the requirements of the EU EMC and LV Directives through testing to EN 61326-1 and EN 61010-1.
External power supply PSE-approved



Footnotes: Specifications are subject to change without notice

- The On/Off ratio for the 'E3' image intensifier in the UV with MCP gating is typically 10^5 .
- Figures are typical unless otherwise stated.
- Typical photocathode Quantum Efficiency and standard quartz input window transmission as measured by the tube manufacturer. MgF_2 window allows extended operation down to 120 nm.
- Typical resolution of the image intensifier tube only, not the overall resolution of the system. As a rough guide, the smallest resolvable FWHM feature will be approximately 2x the CCD pixel size. This is a very important consideration for optical resolution calculations in spectrograph-based systems.
- Gen 2 High QE (H) option – Photocathode QE is inherently linked to the gating speed of the intensifier. High QE option (H) offers higher peak QE than Ultrafast (U) or Fast (F) intensifiers, while exhibiting minimum gating speed one order of magnitude slower.
- Actual measured minimum optical gating of the photocathode, reflecting not only the electrical pulse width applied to the photocathode but also its inherent iris time.
- Gain is software-selectable through a 12-bit DAC and varies exponentially with DAC setting. Value refers to the ratio of max to min intensifier gain as measured for individual cameras. Actual optical gain (counts/photoe) for a DAC setting is accessed by the multiplication of the relative gain (at that DAC value) by the minimum system gain (at DAC = 0, $CCD \epsilon^-$ /photoe) and divided by the sensitivity ($CCD \epsilon^-$ /count) at a given CCD PAG. Sensitivities are individually measured and reported for each system.
- Combination of -73 GaAsP photocathode with a lumogen-coated fibre-optic plate and protective MgF_2 window. The latter additional optical interfaces are the reason for the lowered QE in the visible NIR region, for the -C3 model.
- Measured for the entire system. Combination of CCD readout noise and A/D noise - measurement is for single pixel readout with -30°C CCD cooling and at minimum exposure time under dark conditions. Values quoted are measured with highest available PAG setting.
- Linearity is measured from a plot of counts vs exposure time under constant photon flux up to the saturation point of the system.

Minimum Computer Requirements:

- 3.0 GHz single core or 2.4 GHz multi core processor
- 2 GB RAM
- 100 MB free hard disc to install software (at least 1 GB recommended for data spooling)
- USB 2.0 High Speed Host Controller capable of sustained rate of 40 MB/s
- Windows (XP, Vista, 7 and 8) or Linux

Operating & Storage Conditions

- Operating Temperature: 0°C to 40°C ambient
- Relative Humidity: < 70% (non-condensing)
- Storage Temperature: -20°C to 55°C

Power Requirements

- 100 - 240 VAC, 50 - 60 Hz



Windows is a registered trademark of Microsoft Corporation.
Labview is a registered trademark of National Instruments.
Matlab is a registered trademark of The MathWorks Inc.