

FORMULA

Green Industrial Nanosecond Lasers

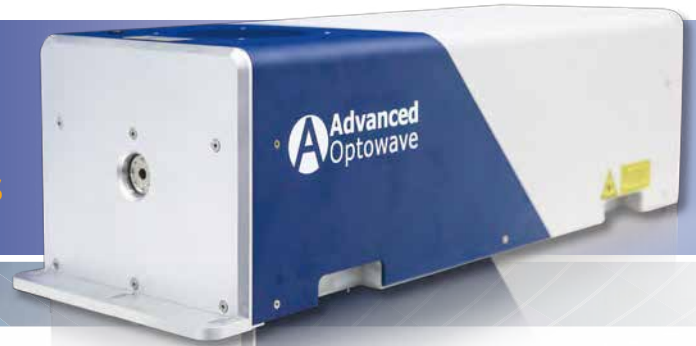

Feature & Benefits :

- All-in-one box design for easy integration
- Lowest Cost of Ownership in the industry
- Power up to 50W
- Excellent beam quality of $M^2 < 1.2$
- Simple and decent software interface
- High reliability for 24/7 applications

Applications :

- PCB/FPC cutting & micro-machining
- Thin film/PI film cutting
- Wafer Scribing
- Solar cell processing

FORMULA 532			
Specification	532-20W-50K	532-35W-50K	532-50W-300K
Wavelength(nm)	532		
Average Power (Watts)	>20W@50KHz	>35W@50KHz	>50W@300KHz
Pulse Energy(μJ)	> 400	>700	>500
Specified Repetition Rate(kHz)	50	50	300
Repetition rate(kHz)	30-150	40~300	
Pulse Width(ns)	< 38	<38	<48
Beam Quality(M^2)	<1.2		
Beam Roundness(%)	>90		
Beam Diameter(mm)	~0.85		
Beam Divergence(mRad)	<2		
Point Stability(μrad/°C)	<20		
Polarization Ratio	1:100 Linear,Vertical		
Pulse-to-Pulse Stability(%RMS)	<3		
Average Power Stability(% over 12 hour)	<3		
Cold Start Warm-up(mins.)	<40		
Stand by Warm-up(mins.)	<10		
Operation Temperature Range(°C)	15 to 35		
Operation Humidity Range(%)	20 to 80,non-condensing		
Storage Temperature Range(°C)	- 20 to 50		
Storage Humidity Range(%)	20 to 80,non-condensing		
Input Voltage(VDC)/Rated Power(W)	24/450		
Communication	RS232		
Cooling	Water		
Weight(kg)	20		

Address : Advanced Optowave Corporation USA 105 Comac
St.Ronkonkoma,NY 11779 USA

Email : info@a-optowave.com URL : www.a-optowave.com TEL :001-631-750-6035

FORMULA UV Industrial Nanosecond Lasers

Typical Performance FORMULA 532-20-50
Power and Energy as a Function of Repetition Rate

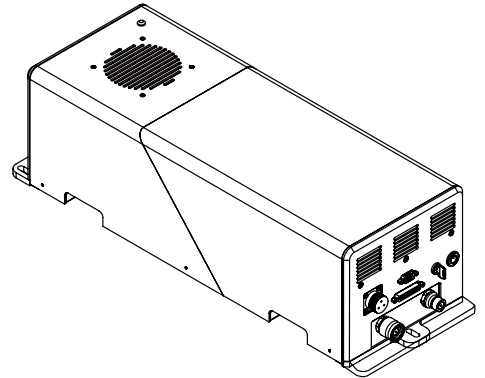
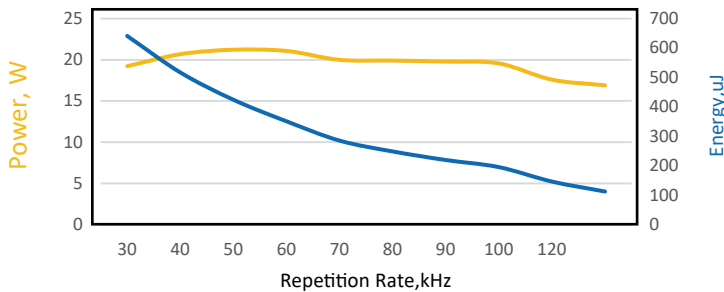

Typical Performance FORMULA 532-35-50
Power and Energy as a Function of Repetition Rate

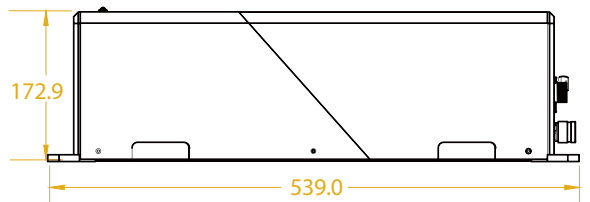
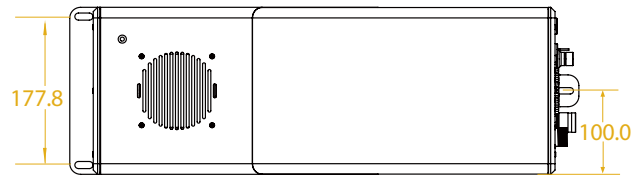
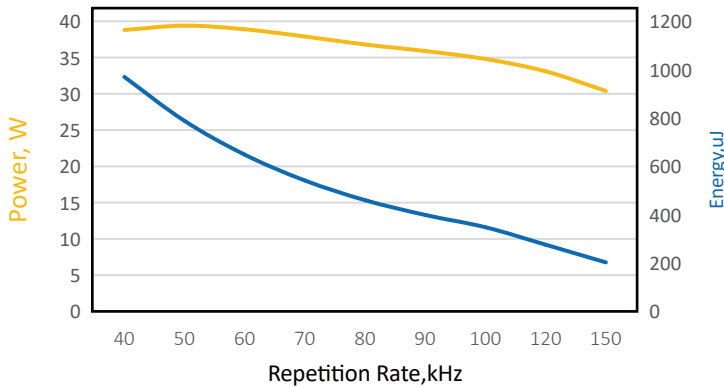

Typical Performance FORMULA 532-50-300
Power and Energy as a Function of Repetition Rate

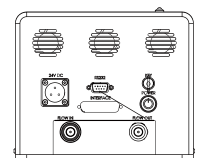
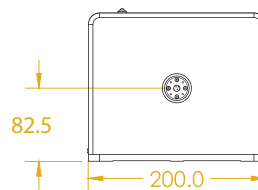
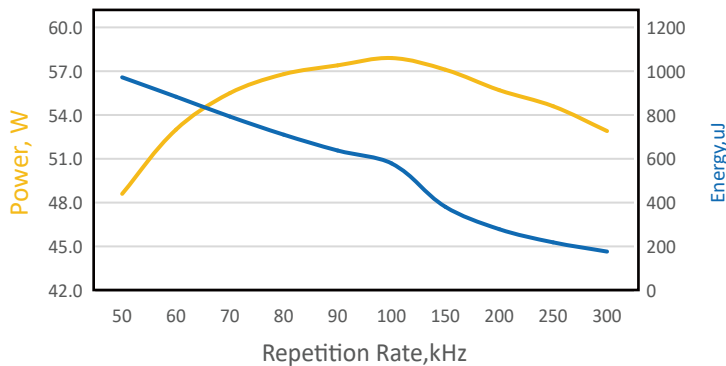

*Advanced Optowave Corporation follows a policy of continuous product improvement. Specifications are subject to change without notice. Advanced Optowave Corporation offers a limited warranty for all Nanosecond UV laser systems. For full details on warranty coverage, or for further product information, please contact us.

