

MOPA 266-50

Diode pumped passively Q-switched solid state laser

- 266 nm
- Single Pulse
- ≤ 1.0 ns
- 1 – 1000 Hz
- > 50 μ J
- External / Internal Trigger Mode



biology · biomedicine · chemistry · analytics

Optical Data	Wavelength	266 nm
	Peak Power	> 50 kW @ 1000 Hz
	Pulse Energy	> 50 μ J @ 1000 Hz
	Beam Divergence (full angle)	< 2.0 mrad
	Beam Ellipticity	$< 2 : 1$
	Beam Diameter	0.5 ± 0.3 mm (at laser exit)
	Spatial Mode	TEM ₀₀
	Pulse Repetition Rate (with external trigger)	1 - 1000 Hz
	Pulse Width (FWHM)	≤ 1.0 ns
	Polarization Ratio	$> 100:1$, vertical
	Pulse Energy Drift ¹⁾	$< \pm 3$ %
	Pulse-to-Pulse Energy Stability ²⁾	< 2 % rms
	Laser Classification	4 / IV
Optical Output	Free Beam	
Electrical Data	Electrical Power Consumption	< 250 W (maximum)
	Line Voltage	100 - 240 V AC (50-60 Hz)
Interface	USB	
	BNC connector for external triggering (TTL)	
	SMB connector for 24 V DC output	
Miscellaneous	Warm-up Time	< 10 min
	Operating Temperature	18 - 38 °C
	Laser Head Size	61 x 150 x 330 mm (H x W x L)
	Stand Alone Unit Size (core size)	184 x 449 x 375 mm (H x W x L)
Options	External telescope (beam expander)	
	Manual or electrical attenuator	
	Synchronization signal output (rise time < 2 ns)	
	Manual or electrical wavelength switch (266nm – 532nm) or electrical beam blocker	
¹⁾ Drift over 8 hours, energy averaged over 10 sec after 5 min of continuous operation, temperature variation ± 3 °C and < 3 °C/hour, with activated closed loop control for the pulse energy ²⁾ RMS over 1000 pulses after 5 min of continuous operation.		

Laser Head and Controller

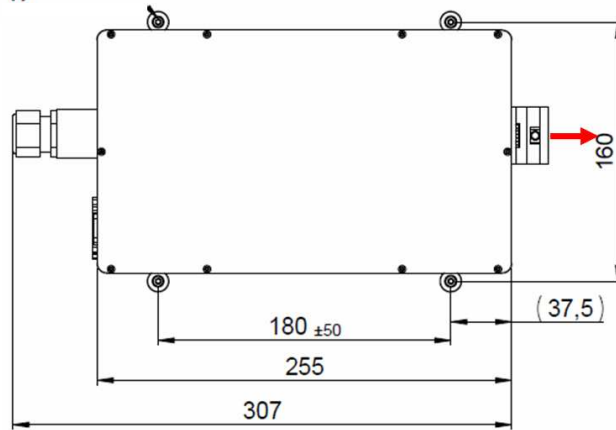
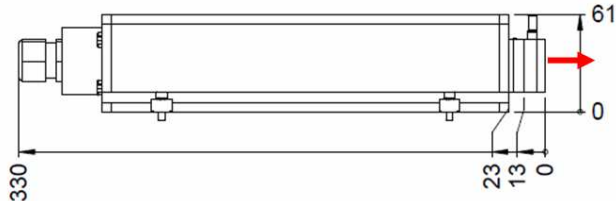
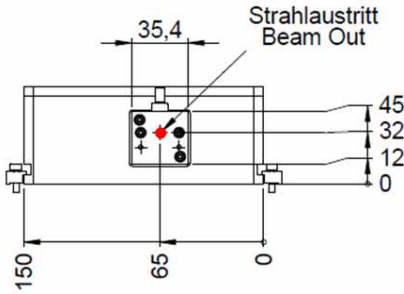

Laser Head
(height = 61; width = 150; length = 255
core dimensions in mm)

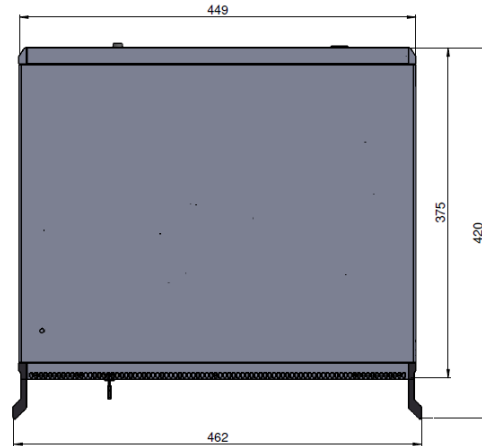
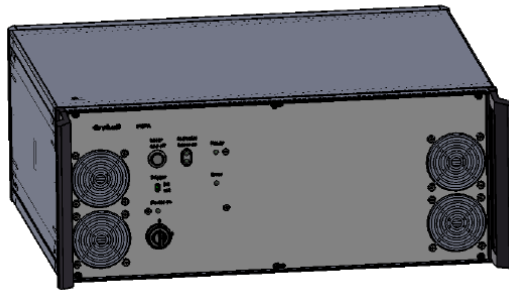

Stand Alone Unit
(height = 184, width = 449; length = 375
core dimensions in mm)

Laser Safety Labels

The MOPA 266-50 lasers are class 4 / IV according to IEC 60825-1:2014

wavelength: 266 nm max. output: 200 µJ pulse duration: < 1.2 ns max. repetition rate: 1000 Hz <small>Complies with IEC 60825-1:2014 Complies with 21CFR 1040.10 and 1040.11 except for deviations pursuant to Laser Notice No. 50, dated July 26, 2001</small>	DANGER - INVISIBLE LASER RADIATION AVOID EYE OR SKIN EXPOSURE TO DIRECT OR SCATTERED RADIATION CLASS 4 LASER PRODUCT	LASER RADIATION IS EMITTED FROM THIS APERTURE
---	---	--

