

## High Energy Broadband Polarizing Cube Beamsplitters

An alternative to calcite and Brewster angle polarizers, the PBSK is an optimal solution for high-energy broadband or multiline systems. Unlike cemented cube polarizers, the PBSK is optically contacted, coated with all-dielectric materials and manufactured from fused silica to ensure high transmission and high damage threshold.

- $\lambda/4$  reflected and transmitted wavefront distortion
- Damage threshold  $5 \text{ J/cm}^2$  at 1064 nm
- Incident and reflected beams separated by  $117^\circ$
- Contact CVI Laser Optics for other designs between 230 nm and 2100 nm

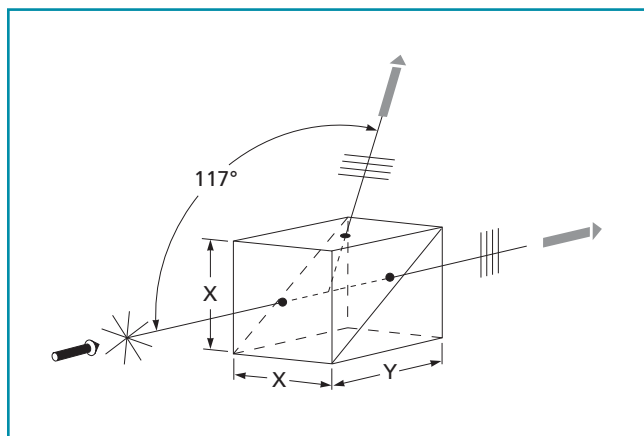

PBSK high energy broadband polarizing beamsplitter cubes

### SPECIFICATIONS:

#### High Energy Broadband Polarizing Cube Beamsplitters

<b>Optical Material</b>	UV-grade fused silica
<b>Edge Dimension</b>	X, Y $\pm 0.25$ mm
<b>Surface Quality</b>	20-10 scratch and dig
<b>Transmitted Wavefront Error</b>	$\lambda/4$ at 633 nm
<b>Extinction Ratio</b>	$T_p/T_s > 1000:1$
<b>Clear Aperture</b>	$\geq 85\%$ of central dimension
<b>Damage Threshold</b>	
	Pulsed $5 \text{ J/cm}^2$ , 20 nsec, 20 Hz @ 1064 nm
	cw $1 \text{ MW/cm}^2$ @ 1064 nm
<b>Antireflection Coating</b>	$R_{\text{avg}} \leq 0.50\%$ , all entrance and exit surfaces

From our Shelves to Your Lab –  
Standard Products for Fast Delivery

#### High Energy Broadband Polarizing Cube Beamsplitters

x × y (mm)	Transmission Efficiency ( $T_p$ )	Wavelength Range (nm)	PART NUMBER
12.7 × 17.5	92%	700–900	PBSK-700-900-050
15.4 × 35.3	92%	700–900	PBSK-700-900-100